

REV	REVISION DESCRIPTION	DATE	SIGNED
03	Improved measurement of system power	20230331	BH
04	Production adjustments	20231124	BH

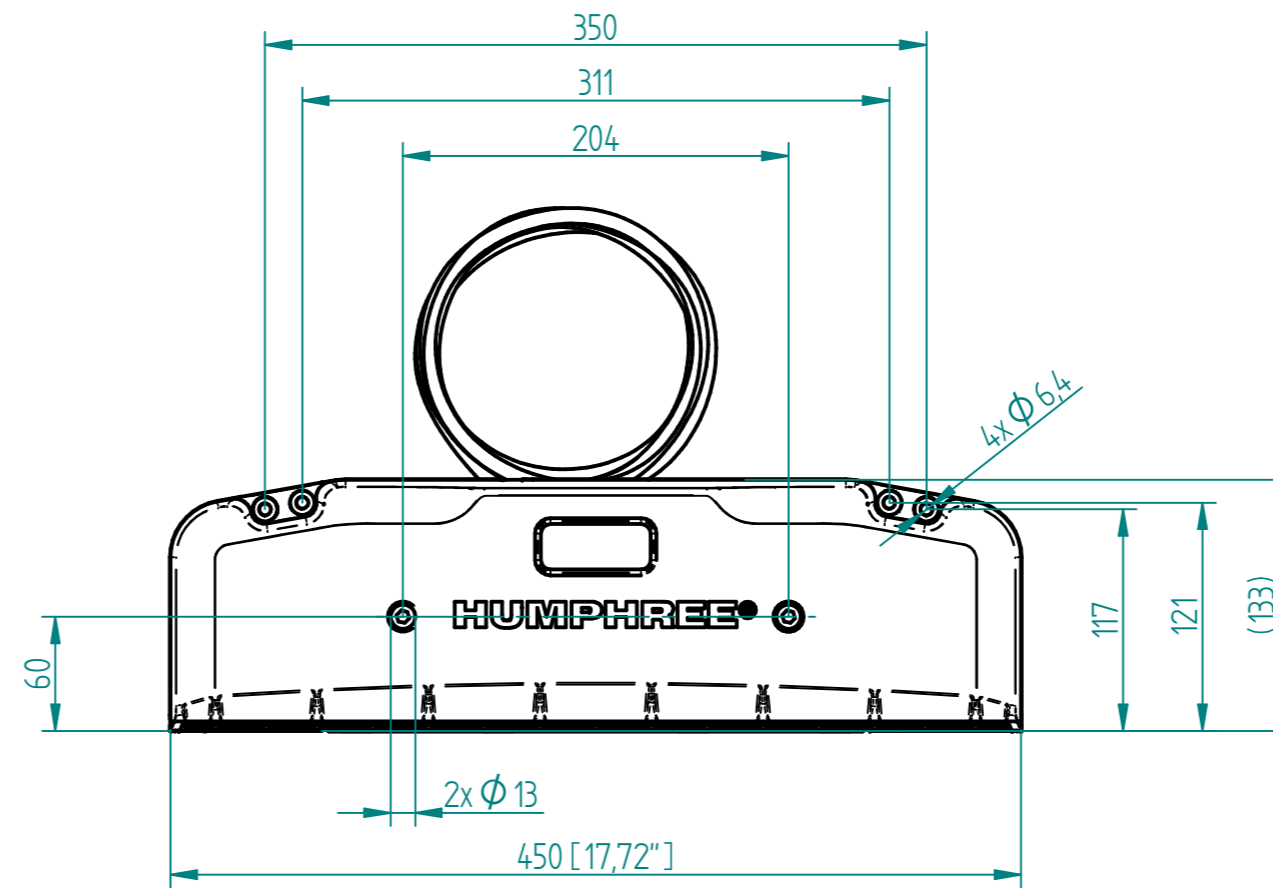
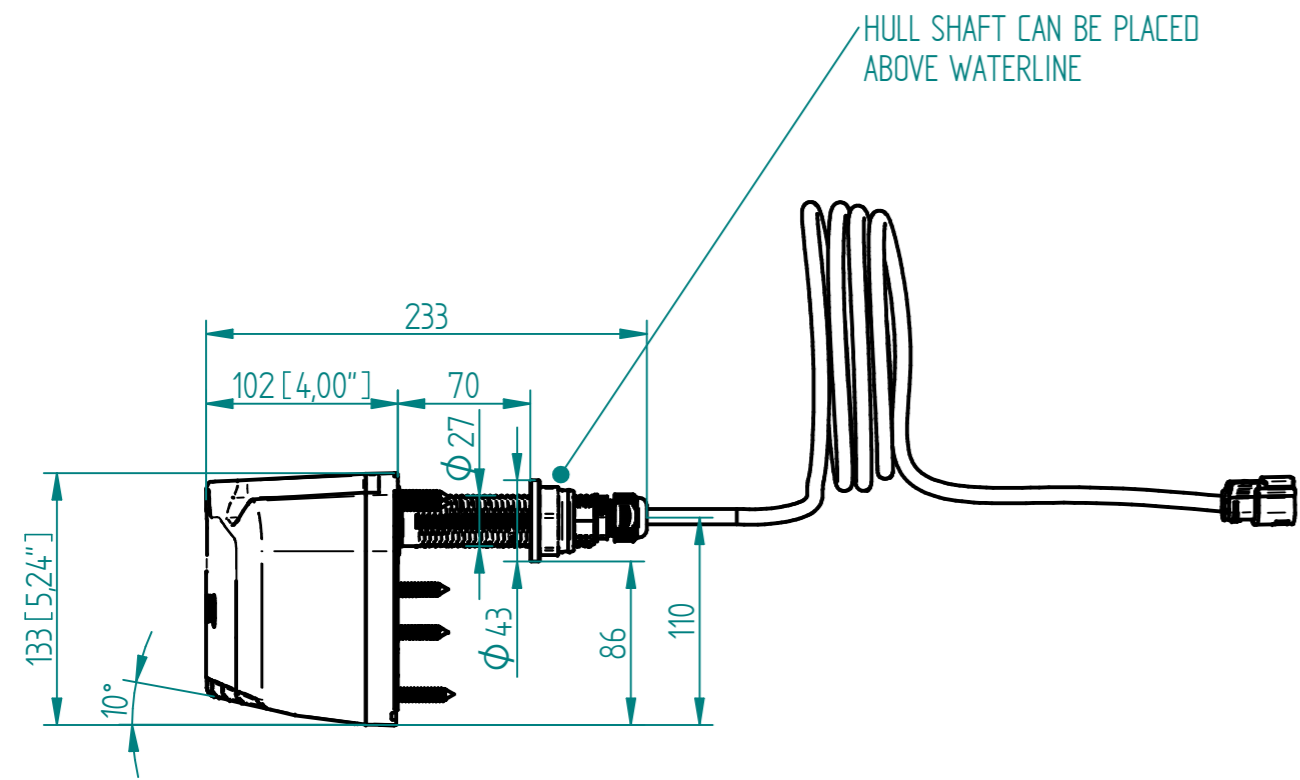

Physical	
Dimensions (L x H x D)	450x133x102 (233) mm
Weight	4,8 kg
Color	Black

Power	
Supply voltage	10-30 VDC
Power consumption	See technical specification
Cable length	4 m

Environmental	
Operating temp.	+1°C to 60°C
Storage temp.	-30°C to 80°C
IP Class (Interceptor + 0,5m of cable from interceptor)	IP68

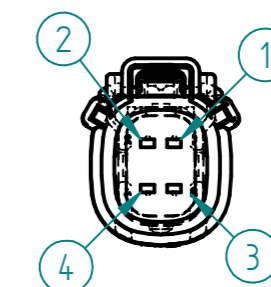
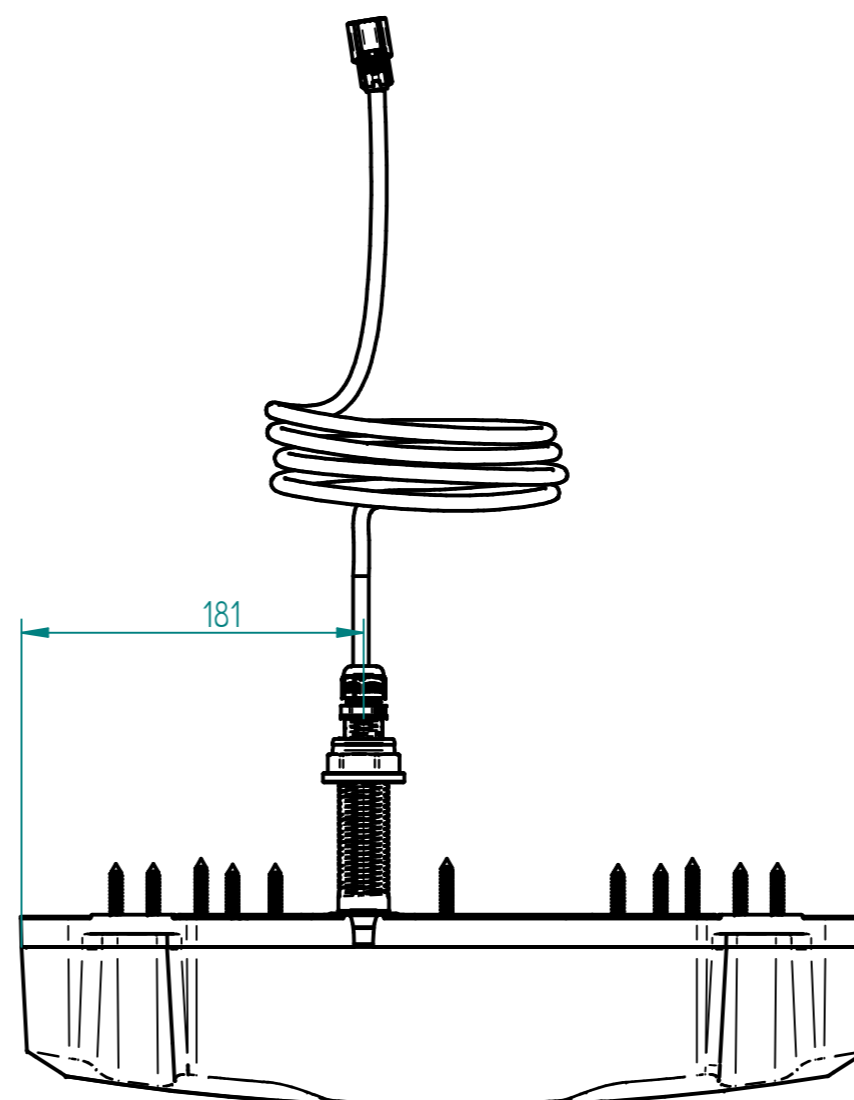
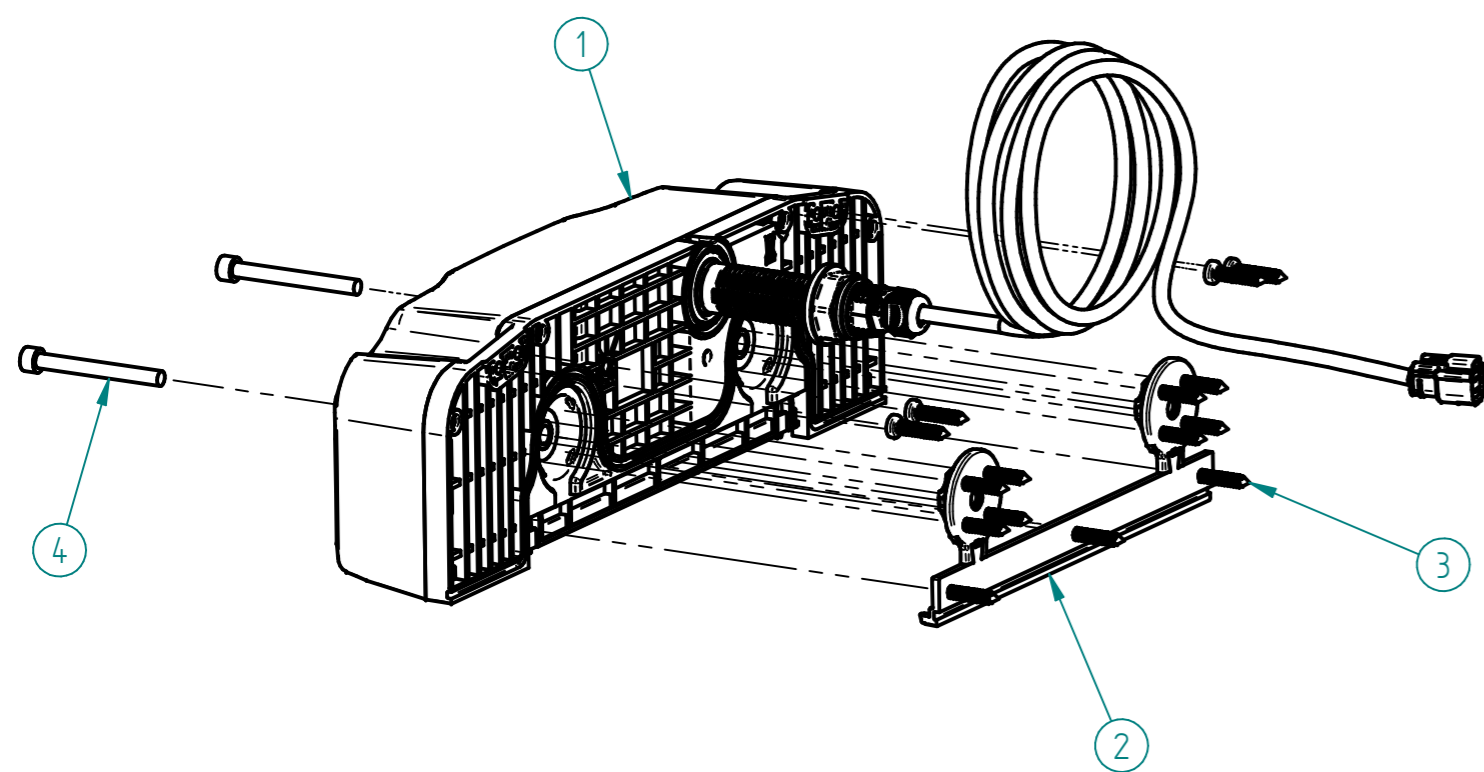

Molex pin	
1	VBAT
2	CAN LO
3	CAN HI
4	GND

SPARE PARTS		
See spare parts drawing 040863 for all lightning spare parts		
ITEM	DESCRIPTION	PART NUMBER
1	L450	023821 (includes 1x023485, 16x023597, 2x011239)
2	Interceptor bracket	023485
3	Screw TX 6.3x32 ISO14585 A4 T30	023597
4	BOLT M8x75 MC6S A4-80 HEX 6	011239

ITEM	QTY	DESCRIPTION	MATERIAL	SIZE	PART NUMBER	REV
This document contains information of a proprietary nature and is delivered on the express condition that it is not to be disclosed, used or reproduced in whole or in part without the written consent of HUMPHREE AB.						DOCUMENT TYPE
FILE NAME						CUSTOMER DRAWING
DEV. STAGE P						RELEASE DATE 2023-11-24
TITLE						STATUS
Interceptor L450 ASM						Released
DATE CREATED 2023-11-29						REV
DRAWN BH CHKD PL APPVD CW						DRAWING NO
www.humphree.com						023821
SIZE SHEET SCALE UNITS: mm						04
A2 1 OF 1 1:4						